

FEATURES

- All difussed design
- High current capabilities
- High surge current capabilities
- High rated voltage
- High dv/dt
- Low gate current
- Dynamic gate
- Low thermal impedance
- Compact size and small weight

APPLICATION

- High Power drives
- DC motor control
- High voltage power cupplies
- Resistance welding



Photo non-contractual

TECHNICAL SPECIFICATION

Electrical properties

Parameter		Test conditions	Value
Repetitive reverse voltage	V_{RRM}	SCTP1900N12	1200 V
		SCTP1900N16	1600 V
Reverse current	I_{RRM}	T_{jmax}	100 mA
Average on-state current	I_{AV}	$T_C=70^{\circ}C$	1900 A
R.M.S. Forward current	I_{RMS}		3000 A
Surge current	I_{TSM}	10ms, T_{jmax} , $0.8V_{RRM}$	30000 A
I^2t value	I^2t		$4500 \times 10^3 A^2s$
On-state voltage max.	V_T	$I_{TM}=1500A$, T_{jmax}	1,05 V
Treshold voltage	V_o		0,74 V
Slope resistance	r_o		0,089 mOhm
Latching current	I_L	$T_j=25^{\circ}C$, $V_D=12V$	1000 mA
Holding current	I_H	$T_j=25^{\circ}C$, $V_D=12V$	250 mA
Circuit conmutated turno-off time (typical)	t_q	$T_j=125^{\circ}C$, $I_{TM}=250A$, $di_R/dt=25A/\mu s$, $V_D=0,67V_{DRM}$, $V_{RM}=100V$.	100 μs
Turn-on time (typical)	t_{on}	$I_{TM}=100A$, $V_{DM}=100V$	12 μs
Rate of change of current	di/dt	$T_j=125^{\circ}C$, $I_{TM}=3I_{AV}$, $V_D=0,67V_{DRM}$, $f=50Hz$, $I_{GM}=1A$, $di_G/dt=1A/\mu s$	200 A/ μs
Rate of rise of voltage	dv/dt	$T_j=125^{\circ}C$, $V_D=0,67V_{DRM}$	1000 V/ μs
Trigger gate current	I_G	$T_j=25^{\circ}C$, $V_D=12V$	200 mA
Gate trigger voltage	V_G	$T_j=25^{\circ}C$, $V_D=12V$	3 V

080521 Rev.:0

Thermal properties

Parameter		Test conditions	Value
Max. operating junction temperature	T_{jmax}		125 °C
Thermal resistance junction-capsule	RTH_{j-c}	DC	0,021 °C/W.
		180° sin	0,021 °C/W.
		120° sin	0,0215 °C/W.
		60° sin	0,0225 °C/W.
Thermal resistance capsule-heatsink	RTH_{c-hs}		0,01°C/W.
Storage temperature	T_{stg}		-40...+125°C

Mechanical properties

Parameter		Value
Weight	M	480 g
Clamping force	m	22,5...25 kN

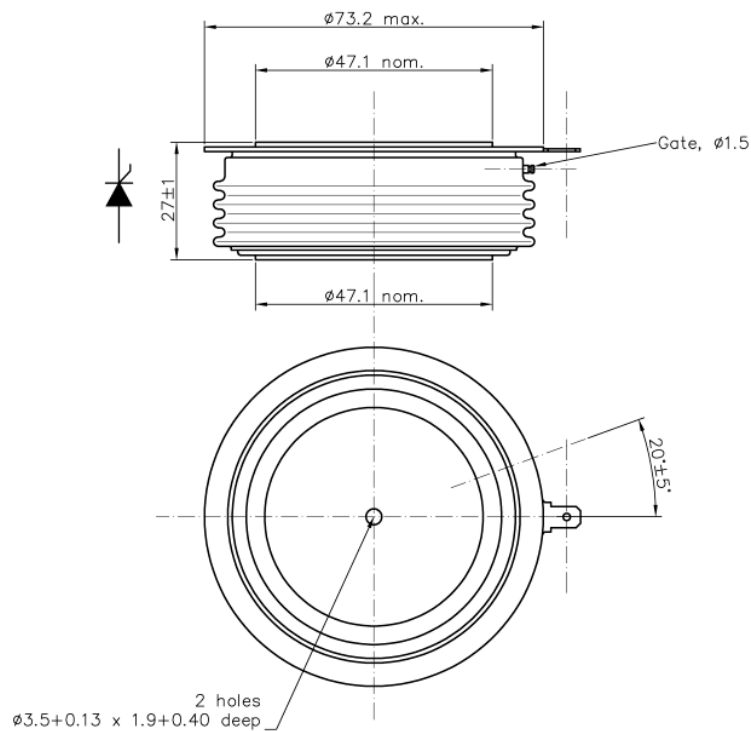

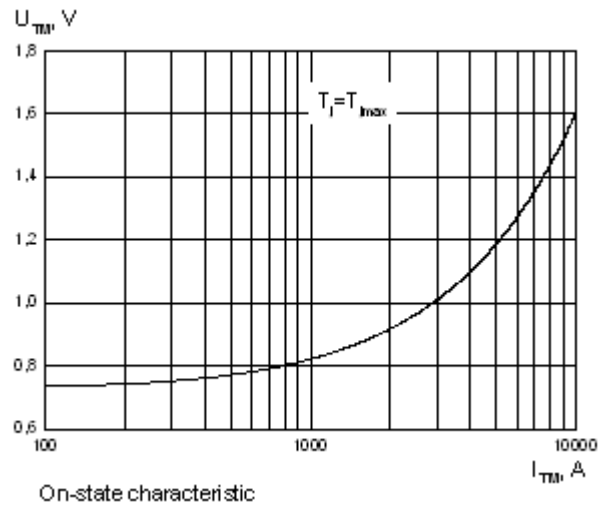
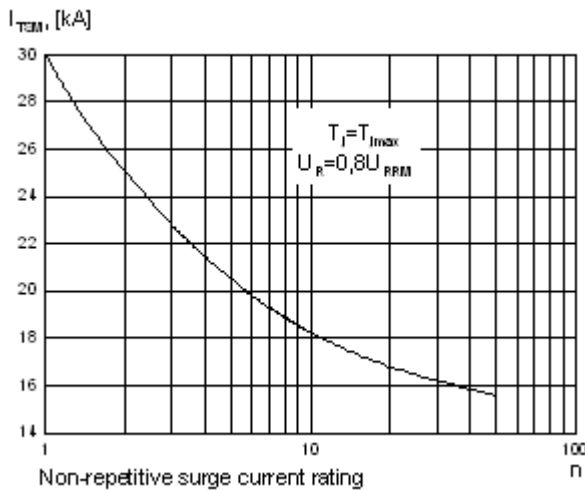
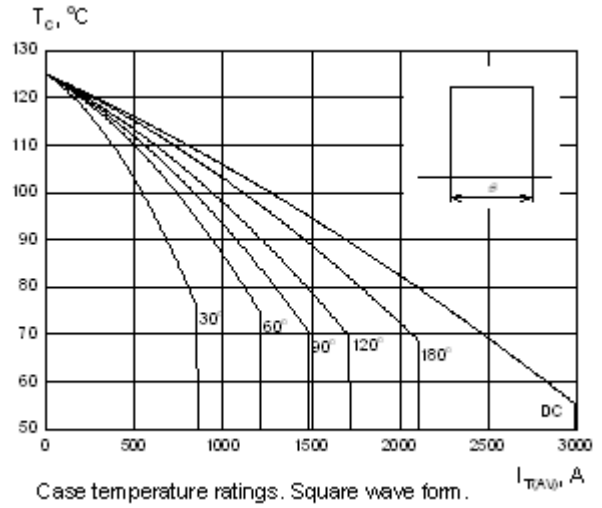
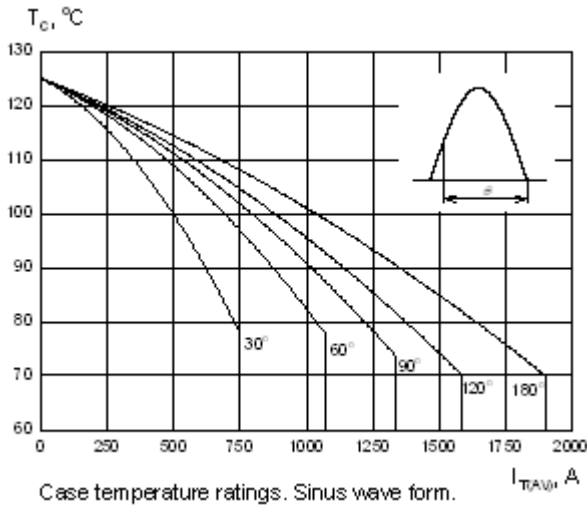
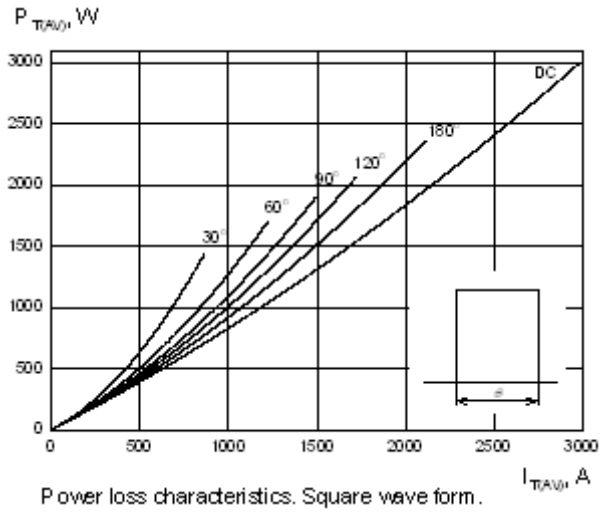
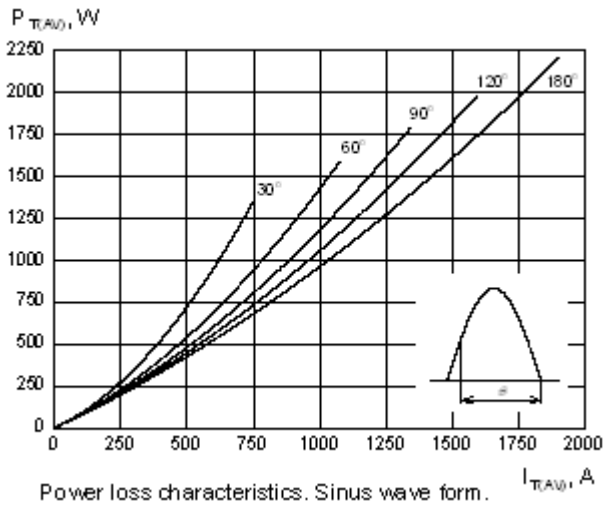

080521 Rev.:0

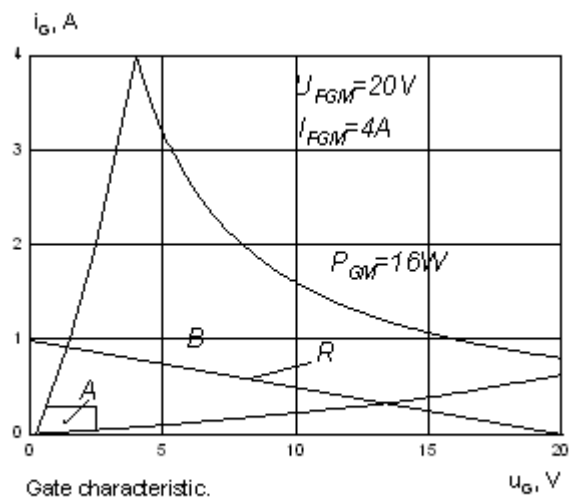
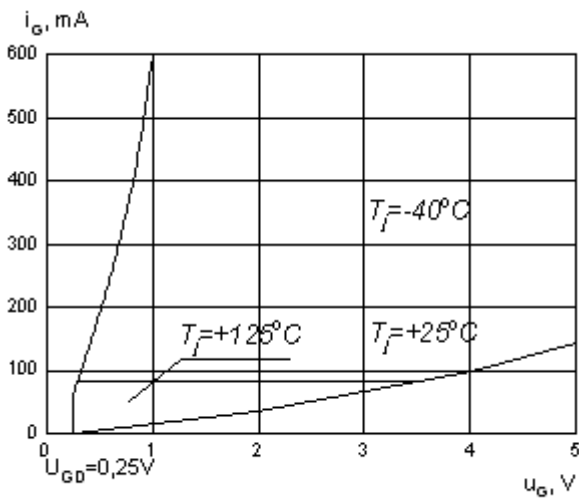
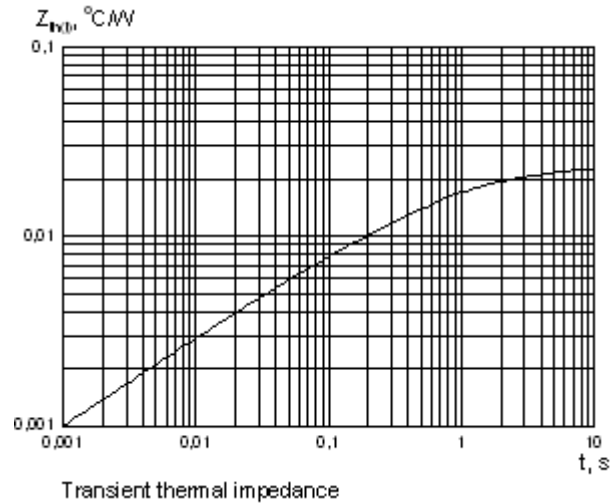

Cost Effective Products

SEMICODE ELECTRONICA

offers to the market a comprehensive range of products from recognized manufacturers at the best price/quality relationship, this products are provided with a basic reference code that allows maintaining the same product reference even if the original device manufacturer is replaced. SEMICODE product reference has to be considered as a generic brand.

Seeking the market needs and trends, we are constantly increasing the product portfolio with new products and suppliers, please ask for the updated information available to our local contacts.

SEMICODE products include semiconductors, passive components and accessories focused in power electronics market.

Datasheet Annotations:

SEMICODE ELECTRONICA annotate datasheets in the top left hard corner of the front page, to indicate product status. The annotations are as follows:

Tentative information: This is the most tentative form of information and represents a very preliminary specification. No actual design work on the product has been started.

Preliminary Information: The product is in design and development. The datasheet represents the product as it is understood but details may change.

Advance Information: The product design is complete and final characterisation for volume production is well in hand.

No Annotation: The product parameters are fixed and the product is available to datasheet specification.

NOTICE: The technical data are to specify components, not to guarantee their properties.No warranty or guarantee expressed or implied is made regarding delivery or performance. The Company reserves the right to alter without prior notice the specification of any product. Information concerning possible methods of use is provided as a guide only and does not constitute any guarantee that such methods of use will be satisfactory in a specific piece of equipment. It is the user's responsibility to fully determine the performance and suitability of any equipment using such information and to ensure that any publication or data used is up to date.

All brand names and product names used in this publication are trademarks, registered trademarks or trade names of their respective owners.

© SEMICODE ELECTRONICA 2008. TECHNICAL DOCUMENTATION – NOT FOR RESALE