

FEATURES

- Fast response time
- High performande clamping voltage characteristics
- Low standby power

APPLICATIONS

- Diode, thyristor and triac voltage protection.
- Surge protection in industrial electronics



Photo non-contractual

MODULE METAL OXIDE VARISTORS

Type	V _{RMS}	V _{DC}	Energy (J)		Surge current	Varistor voltage (V)			Max. Clamping
			10/1000µs	2ms		Nom	Min	Max	
SCV0590MA01	590	785	364	260	6500 A	950	860	1050	1580
SCV0670MA01	670	880	406	290		1070	963	1177	1770
SCV0750MA01	750	960	546	390		1170	1053	1287	1950
SCV0840MA01	840	1120	448	320		1360	1224	1496	2240
SCV0920MA01	920	1230	532	380		1500	1350	1650	2480
SCV0960MA01	960	1255	630	450		1530	1377	1683	2540
SCV1000MA01	1000	1280	728	520		1560	1404	1716	2600
SCV1050MA01	1050	1400	630	450		1700	1535	1875	2820
SCV1170MA01	1170	1550	714	510		1890	1701	2079	3130
SCV1260MA01	1260	1680	672	480		2040	1836	2244	3360
SCV1340MA01	1340	1790	756	540		2180	1962	2398	3600
SCV1380MA01	1380	1845	798	570		2250	2025	2475	3720
SCV1480MA01	1480	1955	798	570		2390	2151	2629	3950
SCV1550MA01	1550	2055	896	640		2500	2250	2750	4130
SCV1630MA01	1630	2165	980	700		2640	2376	2904	4370
SCV1680MA01	1680	2240	896	640		2720	2448	2992	4480
SCV1840MA01	1840	2460	1064	760		3000	2700	3300	4960
SCV1940MA01	1940	2570	1064	760		3140	2826	3454	5190
SCV2300MA01	2300	3075	1330	950		3750	3375	4125	6200
SCV2400MA01	2400	3185	1330	950		3890	3501	4279	6430

Other values under request.

GENERAL CHARACTERISTICS (MA SERIES)	
Capsule	Plastic package & epoxi resin
Flammability rating	UL94-V0
Weight	Aprox.70 grs.

DIMENSIONS

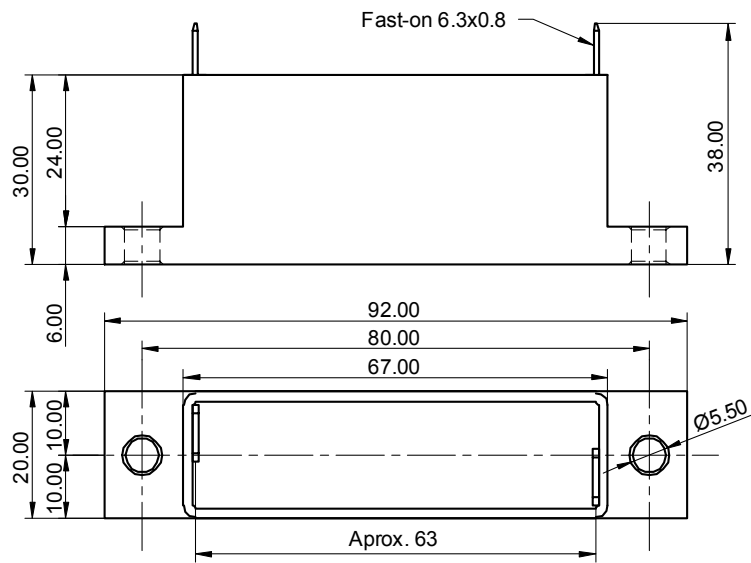

PRECAUTIONS

Should the varistor be subjected to surge currents and high energy levels above maximum ratings, it may physically fail by package rupture or expulsion of material.

It is recommended locate the varistor away from other components or be physically shielded from them.

Power dissipation capability is not necessary for a suppressor, unless transients will be occurring in rapid succession. The operating values need to be derated at high temperatures as shown in graph.

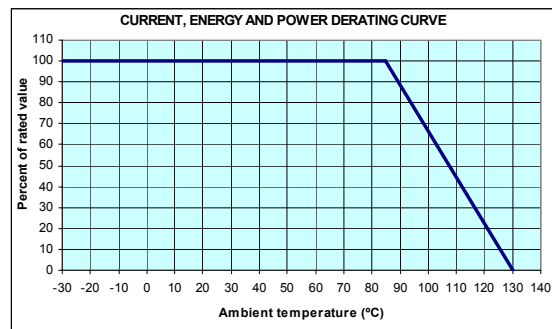

Cost Effective Products

SEMICODE ELECTRONICA

offers to the market a comprehensive range of products from recognized manufacturers at the best price/quality relationship, this products are provided with a basic reference code that allows maintaining the same product reference even if the original device manufacturer is replaced. SEMICODE product reference has to be considered as a generic brand.

Seeking the market needs and trends, we are constantly increasing the product portfolio with new products and suppliers, please ask for the updated information available to our local contacts.

SEMICODE products include semiconductors, passive components and accessories focused in power electronics market.

Datasheet Annotations:

SEMICODE ELECTRONICA annotate datasheets in the top left hard corner of the front page, to indicate product status. The annotations are as follows:

Tentative information: This is the most tentative form of information and represents a very preliminary specification. No actual design work on the product has been started.

Preliminary Information: The product is in design and development. The datasheet represents the product as it is understood but details may change.

Advance Information: The product design is complete and final characterisation for volume production is well in hand.

No Annotation: The product parameters are fixed and the product is available to datasheet specification.

NOTICE: The technical data are to specify components, not to guarantee their properties.No warranty or guarantee expressed or implied is made regarding delivery or performance. The Company reserves the right to alter without prior notice the specification of any product. Information concerning possible methods of use is provided as a guide only and does not constitute any guarantee that such methods of use will be satisfactory in a specific piece of equipment. It is the user's responsibility to fully determine the performance and suitability of any equipment using such information and to ensure that any publication or data used is up to date.

All brand names and product names used in this publication are trademarks, registered trademarks or trade names of their respective owners.

© SEMICODE ELECTRONICA 2008. TECHNICAL DOCUMENTATION – NOT FOR RESALE